

Sectional Table

Part No	Description	QTY.
1	ADJUSTABLE LEG EXTENTIONS	6
2	POST	6
3	TOP BRACE	1
4	END CAP(TABLE WIDTH) MITERED BOTH ENDS	2
5	NOT APPLICABLE	
6	DIAGONAL CORNER BRACE	8
7	STRAIGHT BRACE	4
8	CORNER BRACE 2-LEFT 2-RIGHT	4
9	5/16 X 3/4" HEX HEAD BOLT SURRATED FLANGE NUT	70
10	1/2 X 7/8" HEX HEAD BOLT SURRATED FLANGE NUT & WASHER	6
11	BOTTOM BRACE	3
12	STEEL SPLINE (SEE NOTE 1&2)	
13	#12 X 3/4" TYPE A SHEET METAL SCREW	24
14	APRON RAIL(LENGTH) LEFT HAND MITERED ONE END	2
15	APRON RAIL(LENGTH) RIGHT HAND MITERED ONE END	2

64-2005

NOTES:

THREE 3-3/4" PIECES REQ. FOR 24" & 30" WIDE TABLES
 FOUR 3-3/4" PIECES REQ. FOR 36" - 48" WIDE TABLES
 SIX 3-3/4" PIECES REQ. FOR 54" - 78" WIDE TABLES

TABLE ASSEMBLY INSTRUCTIONS

1. Connect adjustable leg extension (#1) to post (#2) using 1/2" x 7/8" hex head bolt, washer & surrated flange nut.
2. Attach leg assemblies to bottom brace (#11) using 5/16 x 3/4" hex bolts & surrated flange nuts.
3. Assemble top brace(#3) and apron rail(#5) to leg assembly using 5/16 x 3/4" hex bolts & 5/16-18 surrated flange nuts.
4. Add diagonal (#6) & straight corner brace (#7) as per drawing using 5/16 x 3/4" hex bolt & 5/16" surrated flange nut.
5. Repeat above steps on all center sections of framework. End sections of framework are in large cartons marked sectional which finish off each end of the table.
6. Place table tops with spline on steel framework starting in the middle working both directions or start on one end and work to the other end.
7. Attach spline (#12) to top brace using 5/16 x 3/4" hex bolt. Leave bolts loose until all tops are in place & properly aligned.
8. Adjust table to proper height making sure the table is straight & then tighten all the hardware.
9. Install the #12x3/4" screws in tops around perimeter through holes provided in aprons. Must drill 1/8"x1/2" deep pilot holes.

NOTE: Disregard these instructions for X-pand-X tables 84" & wider.

PHILLOCRAFT SECTIONAL TABLE ENDLESS / ADD-ON TABLE

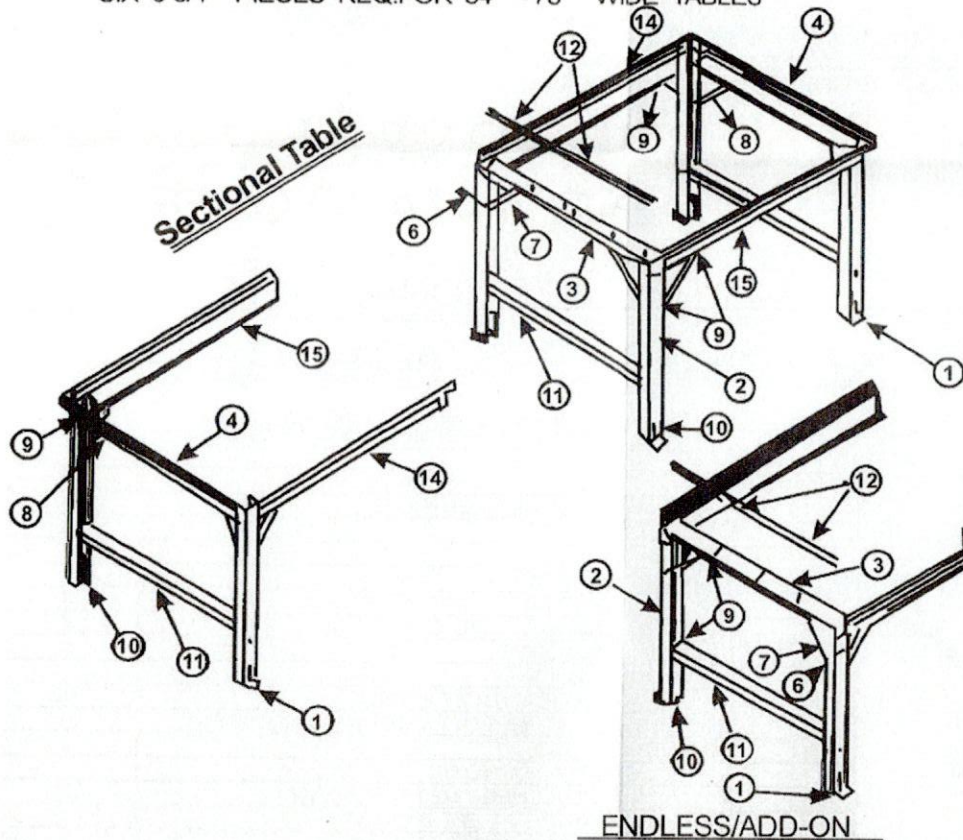

ENDLESS/ADD-ON
LENGTHENS THE TABLE 4'

ENDLESS/ADD-ON TABLE

Part No	Description	QTY.
1	ADJUSTABLE EXTENTIONS	2
2	POST	2
3	TOP BRACE	1
4	NOT APPLICABLE	
5	APRON RAIL(TABLE LENGTH)	2
6	DIAGONAL CORNER BRACE	4
7	STRAIGHT CORNER BRACE	4
8	NOT APPLICABLE	
9	5/16X3/4 HEX HEAD BOLT SURRATED FLANGE NUT	30
10	1/2X7/8 HEX HEAD BOLT SURRATED FLANGE NUT & WASHER	2
11	BOTTOM BRACE	1
12	STEEL SPLINE(SEE NOTE 1&2)	
13	#12X3/4 TYPE A SHEET METAL SCREW	12

64-2000